

SL2-19W-ccc-dd-ee-03-gg-0092

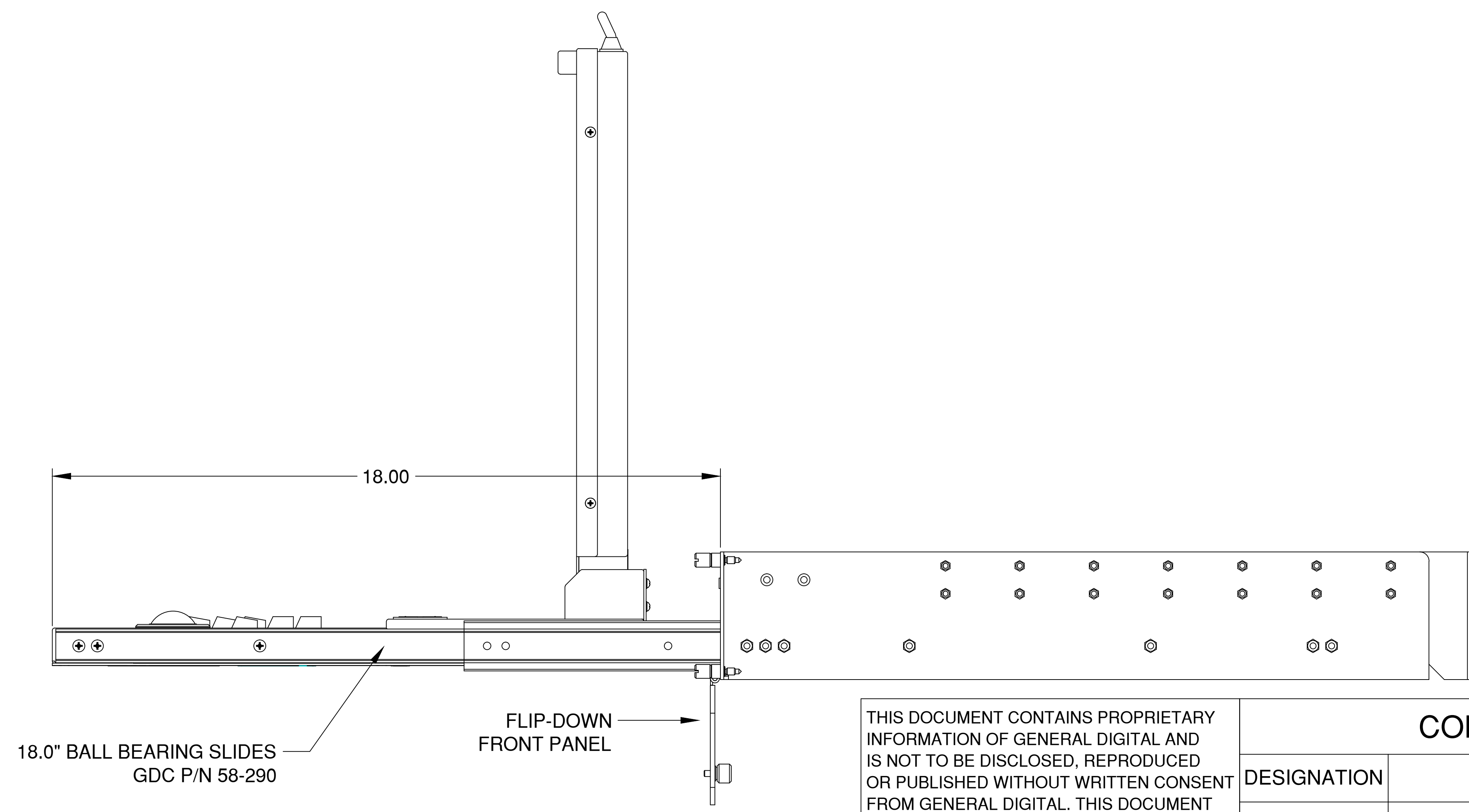
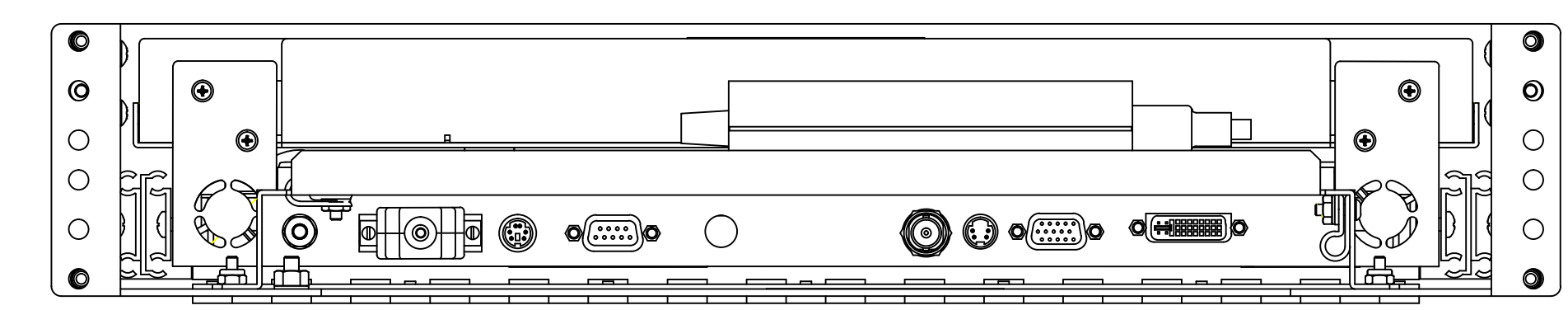
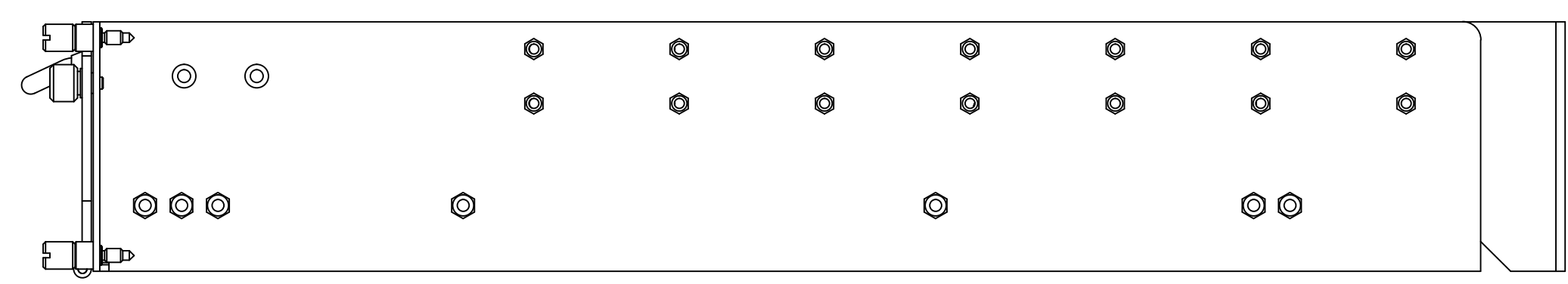
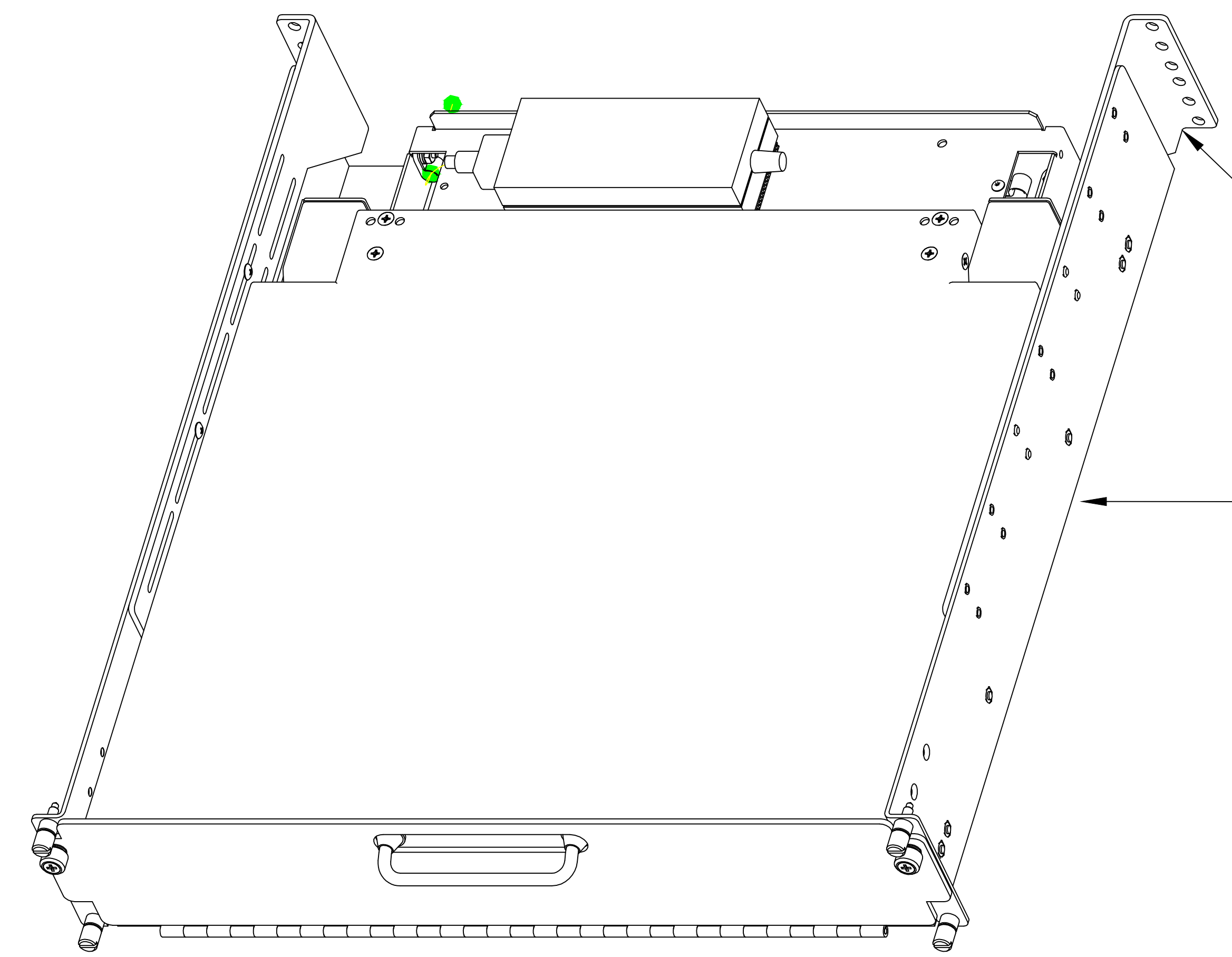
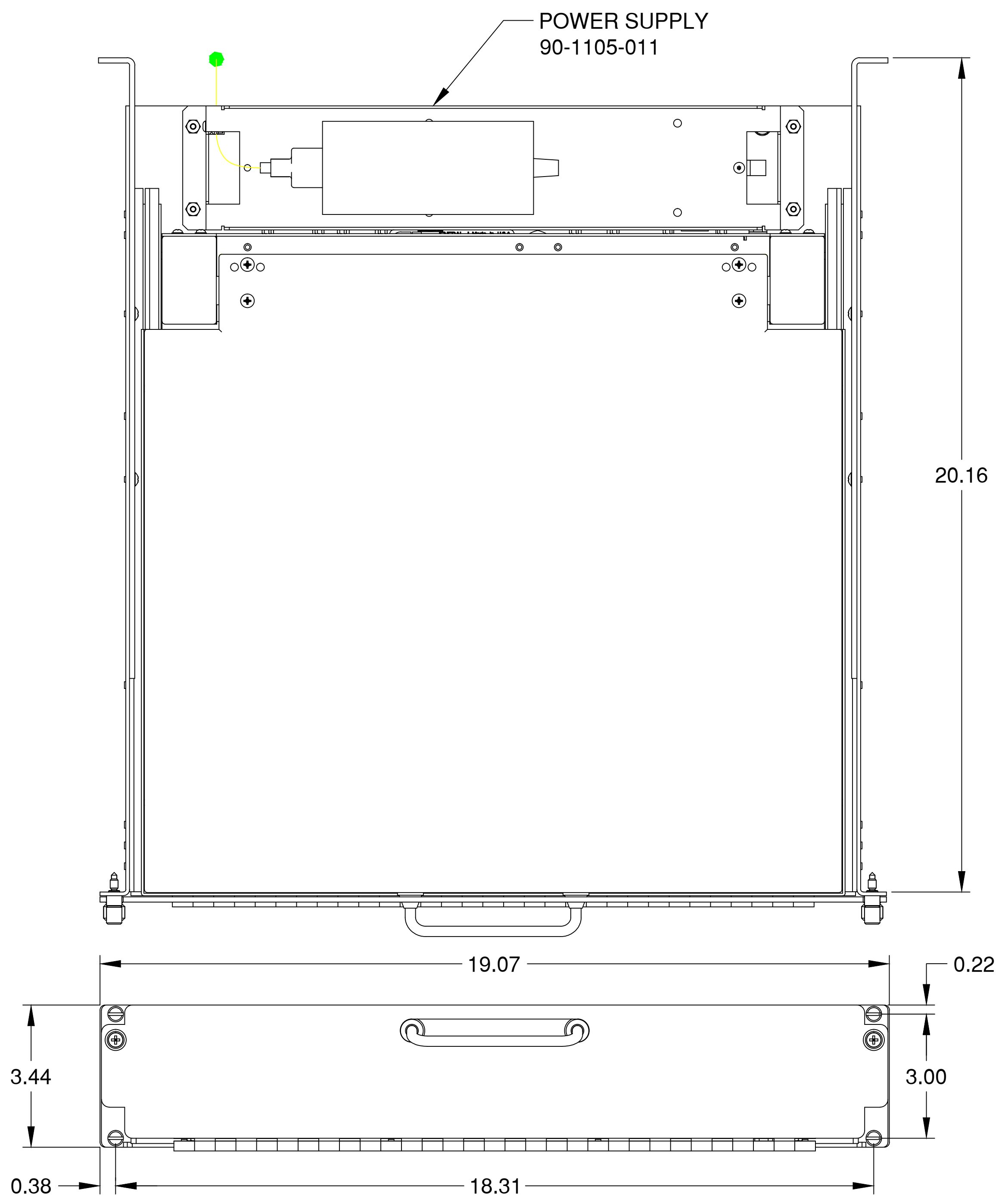

THIS DOCUMENT CONTAINS PROPRIETARY INFORMATION OF GENERAL DIGITAL AND IS NOT TO BE DISCLOSED, REPRODUCED OR PUBLISHED WITHOUT WRITTEN CONSENT FROM GENERAL DIGITAL. THIS DOCUMENT MUST BE RENDERED ILLEGIBLE WHEN BEING DISCARDED. © COPYRIGHT 2011. ALL RIGHTS RESERVED.

UNLESS OTHERWISE SPECIFIED DIMENSIONS ARE IN INCHES
TOLERANCES ARE:
FRACTIONS DECIMALS ANGLES
±1/32 .X ±.050 ±0° 30'
.XX ±.031
.XXX±.020

CONNECTOR CHART		
DESIGNATION	FUNCTION	TYPE

MECHANICAL OUTLINE ONLY. SPECIFICATIONS SUBJECT TO CHANGE WITHOUT NOTICE. U.O.S. ALL DIMENSIONS ARE IN INCHES.

APPROVALS		DATE
DRAWN	G.L.	28-JUNE-13
CHECKED	T.R.	28-JUNE-13
APPROVED	B.G.	28-JUNE-13

DO NOT SCALE DRAWING

GENERAL DIGITAL
The Innovators of Flat Panel Technology
8 Nutmeg Road South, South Windsor, CT 06074
(860) 282-2900 www.GeneralDigital.com

REV	DATE	ECN	DESCRIPTION	CP	BY
-	-	-	-		

SLIMLINE LITE II - GENERAL
19.0" SXGA FLAT PANEL MONITOR

B	CAGE CODE 1JA77	DWG. NO. 13-61	REV -
----------	--------------------	-------------------	----------