

# CUSTOMER APPROVAL

COMPANY

NAME (PRINT)

DATE

SIGNATURE

2215-008-97

90-2215-008

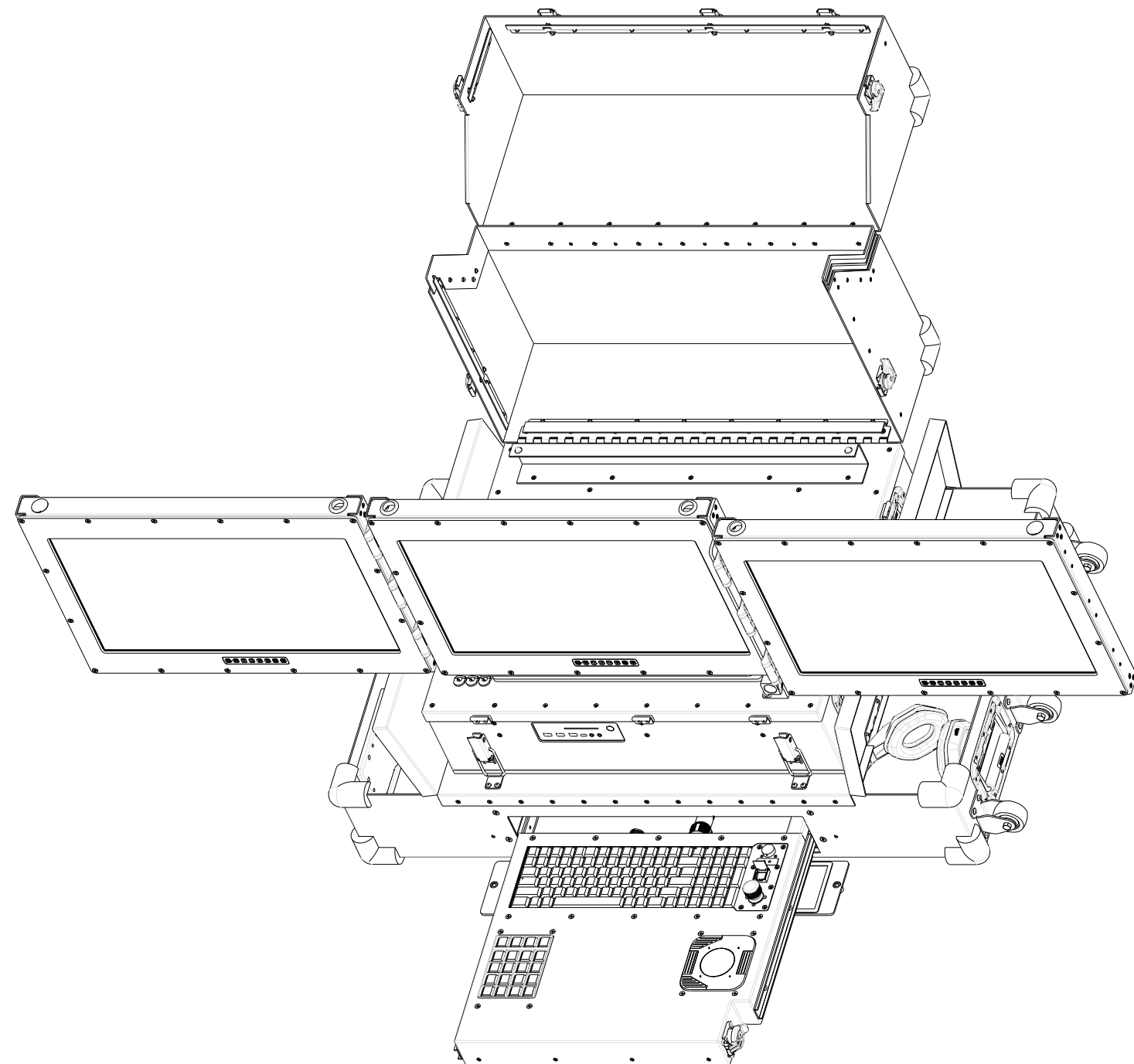

TOP VIEW SHOWING OPEN STORAGE COMPARTMENTS

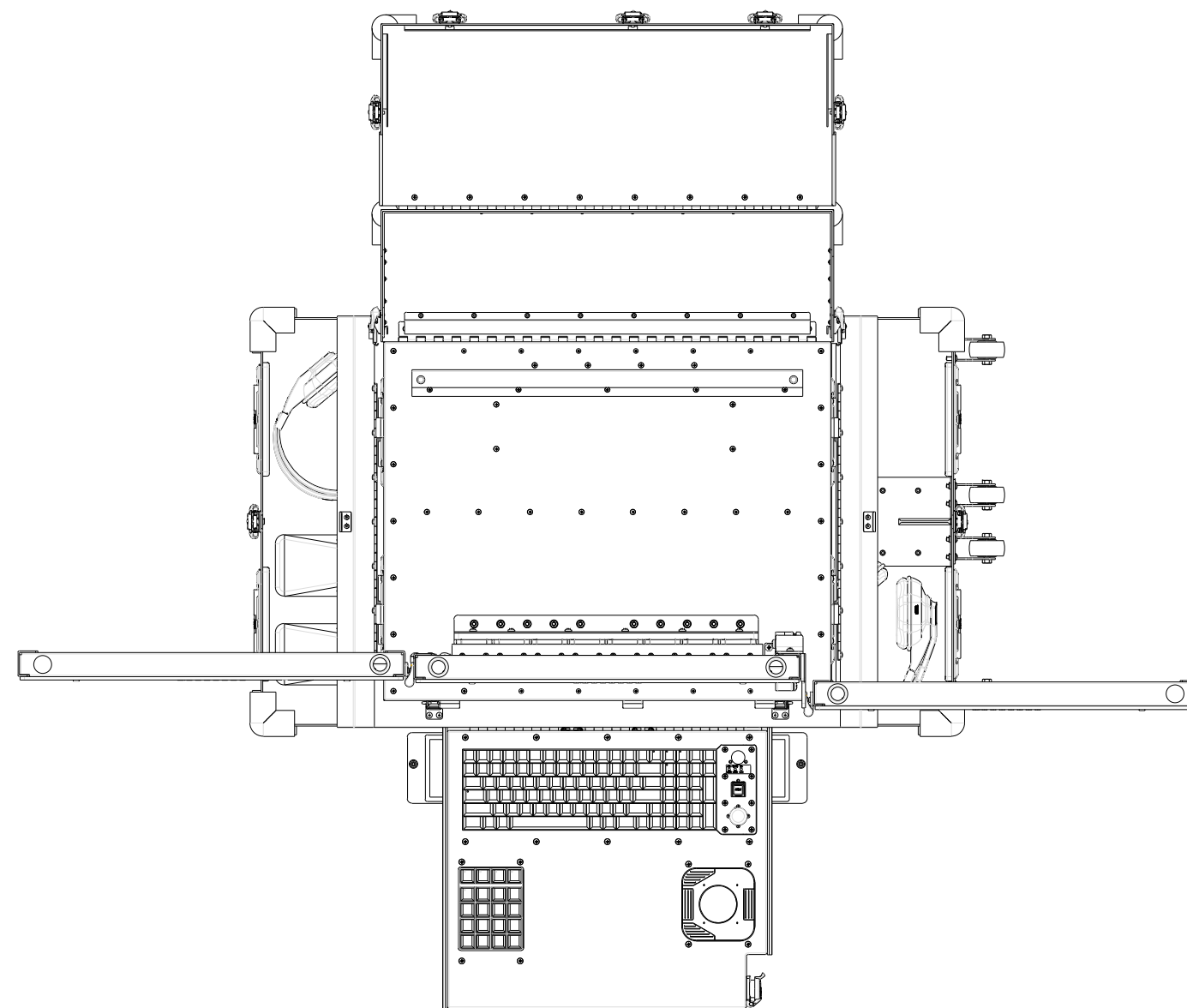

SHEET 1 OF 10

COMPLETE UNIT DEPLOYED

THIS DOCUMENT CONTAINS PROPRIETARY INFORMATION OF GENERAL DIGITAL AND IS NOT TO BE DISCLOSED, REPRODUCED OR PUBLISHED WITHOUT WRITTEN CONSENT FROM GENERAL DIGITAL. THIS DOCUMENT MUST BE RENDERED ILLEGIBLE WHEN BEING DISCARDED. © COPYRIGHT 2021. ALL RIGHTS RESERVED.

UNLESS OTHERWISE SPECIFIED DIMENSIONS ARE IN INCHES  
TOLERANCES ARE:  
FRACTIONS DECIMALS ANGLES  
±1/32 .X ±.050 ±0° 30'  
.XX ±.031  
.XXX±.020

## CONNECTOR CHART

MECHANICAL OUTLINE ONLY. SPECIFICATIONS SUBJECT TO CHANGE WITHOUT NOTICE. U.O.S. ALL DIMENSIONS ARE IN INCHES.

APPROVALS		DATE
DRAWN	FA	27-Oct-21
CHECKED		
APPROVED		
DO NOT SCALE DRAWING		



60 Prestige Park Road, East Hartford, CT 06108  
(860) 282-2900 www.GeneralDigital.com

THREE VIEW TACTILE  
21.5" MONITORS

REV	DATE	ECN	DESCRIPTION	BY
-----	------	-----	-------------	----

<b>B</b>	CAGE CODE	DWG. NO.	REV
	1JA77	2215-008-97	-

# CUSTOMER APPROVAL

COMPANY

NAME (PRINT)

DATE

SIGNATURE

2215-008-97

90-2215-008

## COMPLETE UNIT DEPLOYED

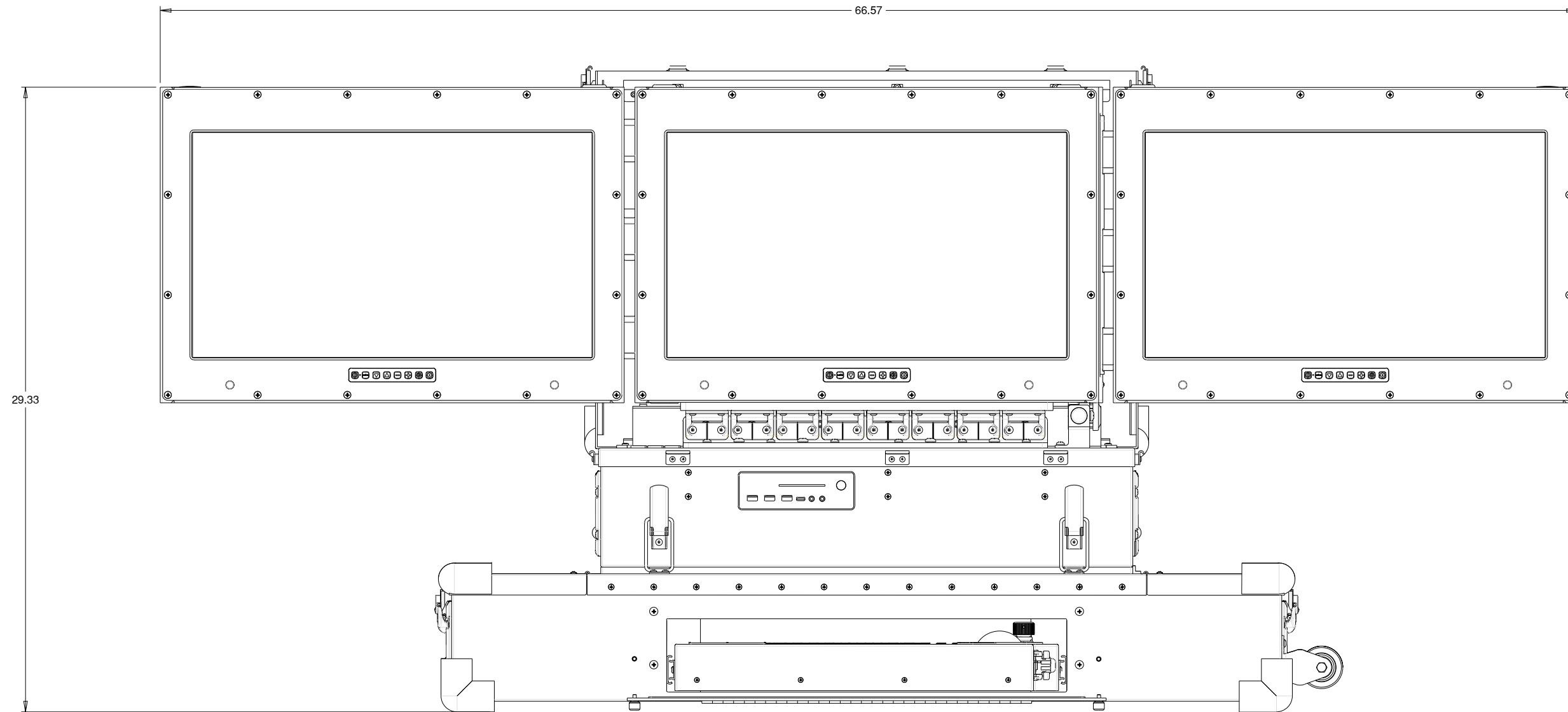

SHEET 2 OF 10

THIS DOCUMENT CONTAINS PROPRIETARY INFORMATION OF GENERAL DIGITAL AND IS NOT TO BE DISCLOSED, REPRODUCED OR PUBLISHED WITHOUT WRITTEN CONSENT FROM GENERAL DIGITAL. THIS DOCUMENT MUST BE RENDERED ILLEGIBLE WHEN BEING DISCARDED. © COPYRIGHT 2021. ALL RIGHTS RESERVED.

UNLESS OTHERWISE SPECIFIED DIMENSIONS ARE IN INCHES  
TOLERANCES ARE:  
FRACTIONS DECIMALS ANGLES  
±1/32 .X ±.050 ±0° 30'  
.XX ±.031  
.XXX±.020

### CONNECTOR CHART

MECHANICAL OUTLINE ONLY. SPECIFICATIONS SUBJECT TO CHANGE WITHOUT NOTICE. U.O.S. ALL DIMENSIONS ARE IN INCHES.

APPROVALS	DATE
DRAWN FA	27-Oct-21
CHECKED	
APPROVED	
DO NOT SCALE DRAWING	



60 Prestige Park Road, East Hartford, CT 06108  
(860) 282-2900 www.GeneralDigital.com

### THREE VIEW TACTILE 21.5" MONITORS

REV	DATE	ECN	DESCRIPTION	BY
-----	------	-----	-------------	----

<b>B</b>	CAGE CODE	DWG. NO.	REV
	1JA77	2215-008-97	-

# CUSTOMER APPROVAL

COMPANY

NAME (PRINT)

DATE

SIGNATURE

2215-008-97

90-2215-008

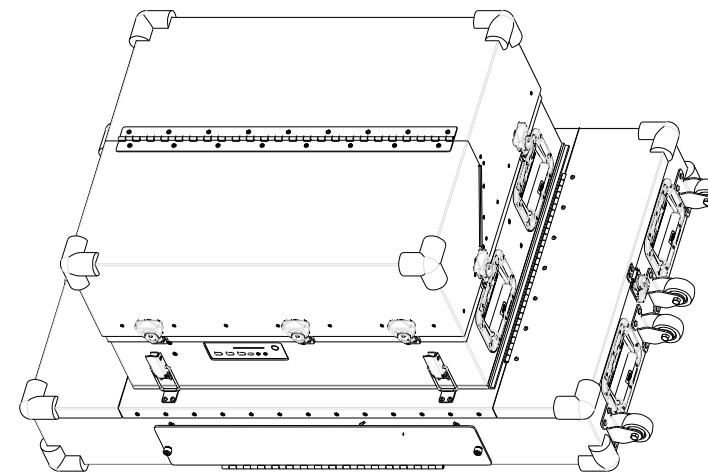
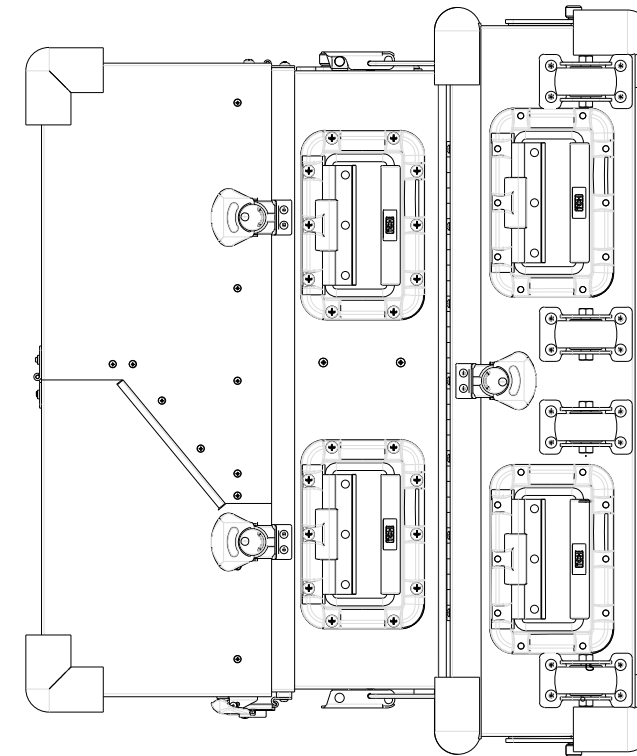
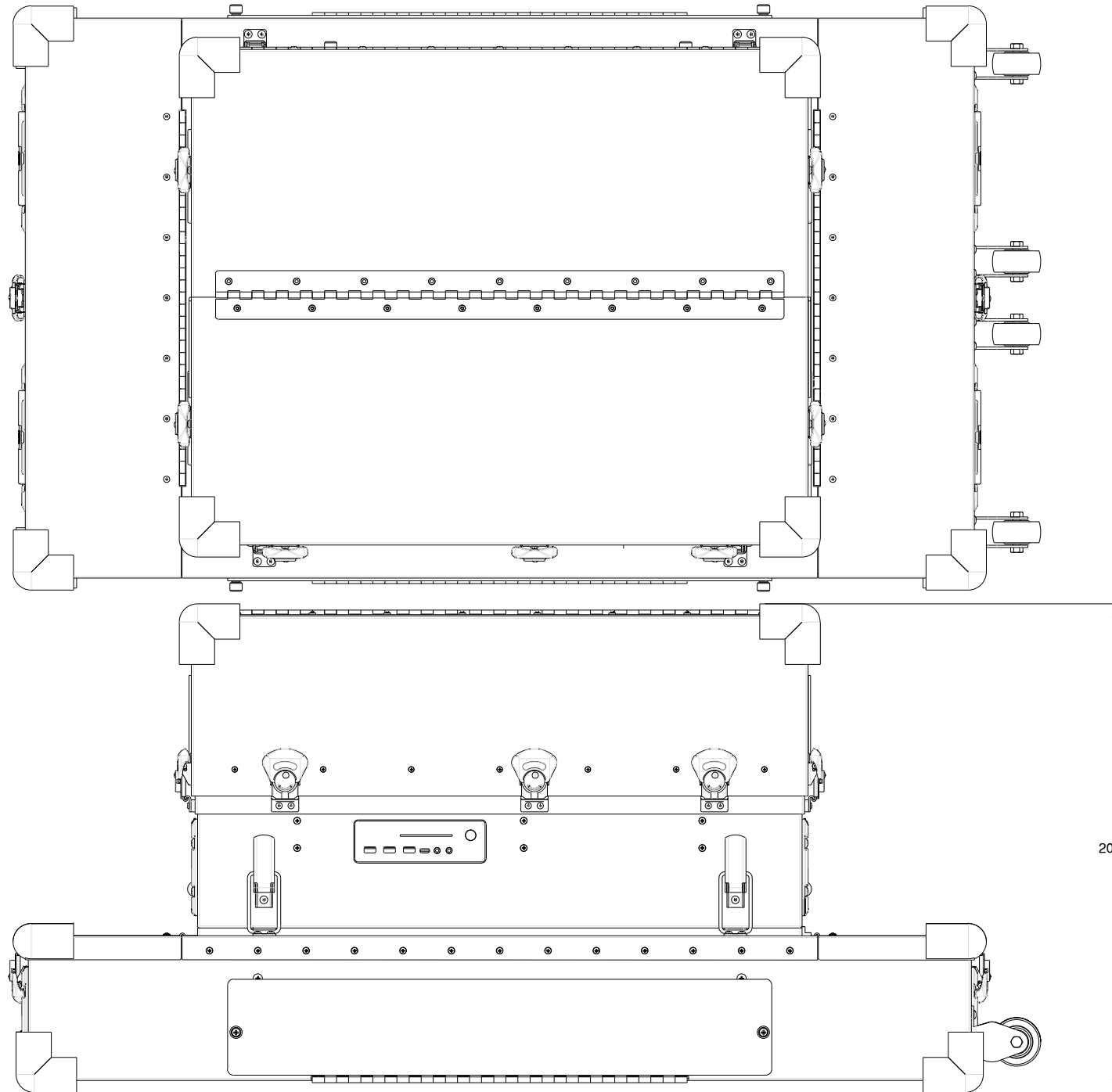

20.21

SHEET 3 OF 10

COMPLETE UNIT STOWED

THIS DOCUMENT CONTAINS PROPRIETARY INFORMATION OF GENERAL DIGITAL AND IS NOT TO BE DISCLOSED, REPRODUCED OR PUBLISHED WITHOUT WRITTEN CONSENT FROM GENERAL DIGITAL. THIS DOCUMENT MUST BE RENDERED ILLEGIBLE WHEN BEING DISCARDED. © COPYRIGHT 2021. ALL RIGHTS RESERVED.

UNLESS OTHERWISE SPECIFIED DIMENSIONS ARE IN INCHES  
TOLERANCES ARE:  
FRACTIONS DECIMALS ANGLES  
±1/32 .X ±.050 ±0° 30'  
.XX ±.031  
.XXX±.020

### CONNECTOR CHART

MECHANICAL OUTLINE ONLY. SPECIFICATIONS SUBJECT TO CHANGE WITHOUT NOTICE. U.O.S. ALL DIMENSIONS ARE IN INCHES.

APPROVALS		DATE
DRAWN	FA	27-Oct-21
CHECKED		
APPROVED		
DO NOT SCALE DRAWING		



60 Prestige Park Road, East Hartford, CT 06108  
(860) 282-2900 www.GeneralDigital.com

THREE VIEW TACTILE  
21.5" MONITORS

REV	DATE	ECN	DESCRIPTION	BY
-----	------	-----	-------------	----

<b>B</b>	CAGE CODE	DWG. NO.	REV
	1JA77	2215-008-97	-

# CUSTOMER APPROVAL

COMPANY

NAME (PRINT)

DATE

SIGNATURE

2215-008-97

90-2215-008

## COMPLETE UNIT DEPLOYED

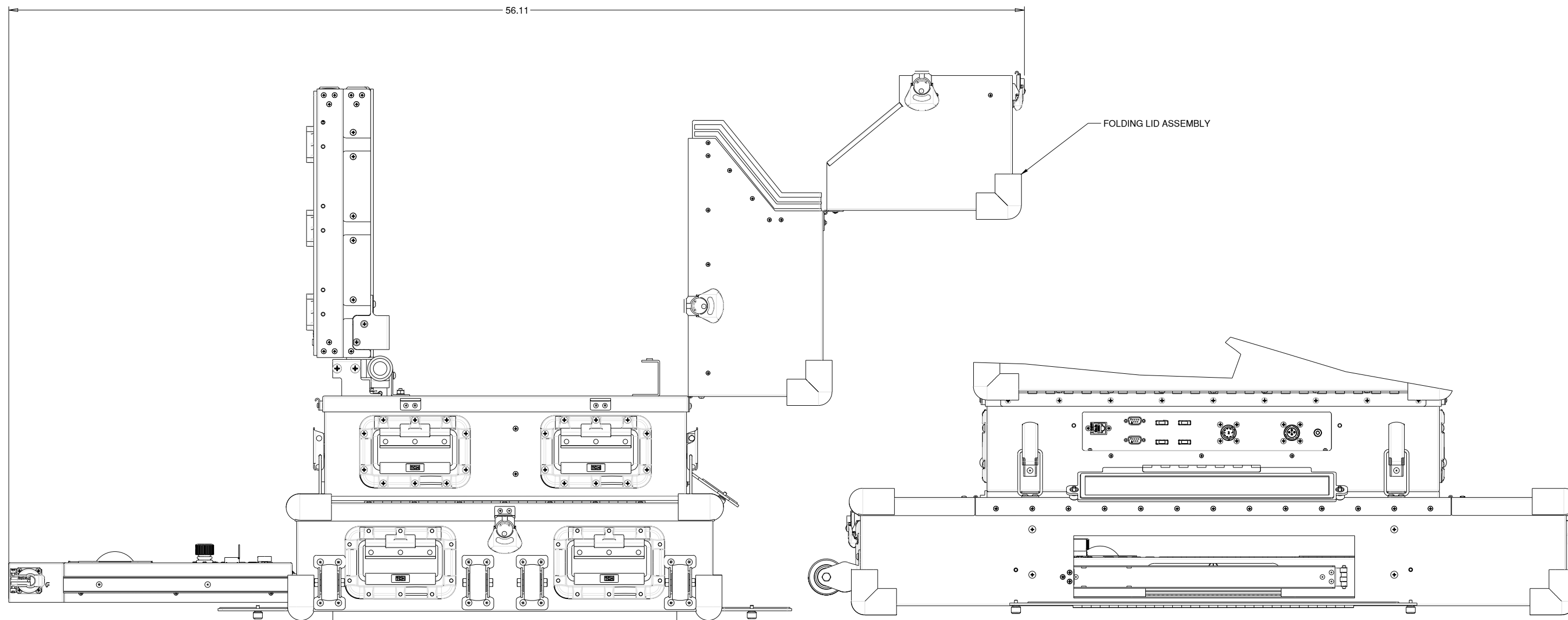

PARTIAL VIEW FROM REAR

SHEET 4 OF 10

THIS DOCUMENT CONTAINS PROPRIETARY INFORMATION OF GENERAL DIGITAL AND IS NOT TO BE DISCLOSED, REPRODUCED OR PUBLISHED WITHOUT WRITTEN CONSENT FROM GENERAL DIGITAL. THIS DOCUMENT MUST BE RENDERED ILLEGIBLE WHEN BEING DISCARDED. © COPYRIGHT 2021. ALL RIGHTS RESERVED.

UNLESS OTHERWISE SPECIFIED DIMENSIONS ARE IN INCHES  
 TOLERANCES ARE:  
 FRACTIONS DECIMALS ANGLES  
 ±1/32 .X ±.050 ±0° 30'  
 .XX ±.031  
 .XXX±.020

### CONNECTOR CHART

MECHANICAL OUTLINE ONLY. SPECIFICATIONS SUBJECT TO CHANGE WITHOUT NOTICE. U.O.S. ALL DIMENSIONS ARE IN INCHES.

APPROVALS	DATE
DRAWN FA	27-Oct-21
CHECKED	
APPROVED	
DO NOT SCALE DRAWING	



60 Prestige Park Road, East Hartford, CT 06108  
 (860) 282-2900 www.GeneralDigital.com

### THREE VIEW TACTILE 21.5" MONITORS

<b>B</b>	CAGE CODE	DWG. NO.	REV
	1JA77	2215-008-97	-

REV	DATE	ECN	DESCRIPTION	BY

# CUSTOMER APPROVAL

COMPANY  
DATE

NAME (PRINT)  
SIGNATURE

2215-008-97

90-2215-008

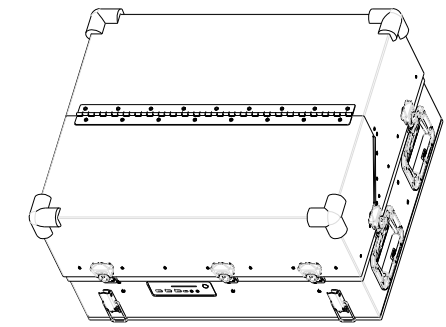
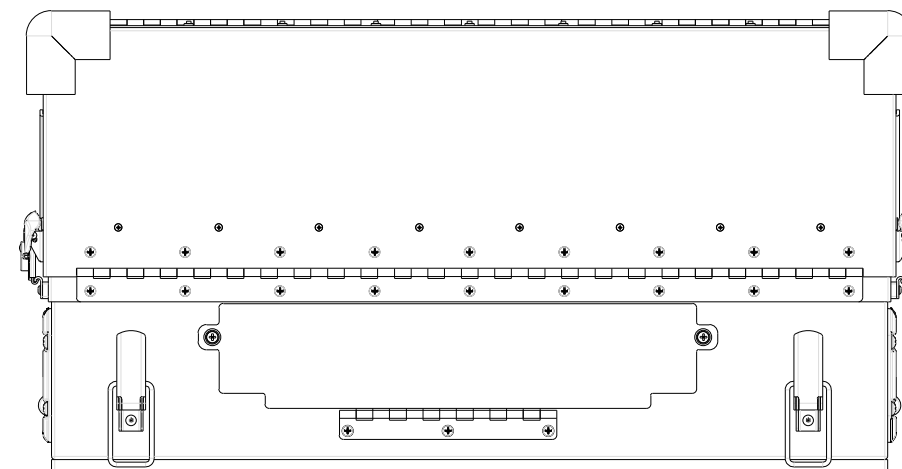
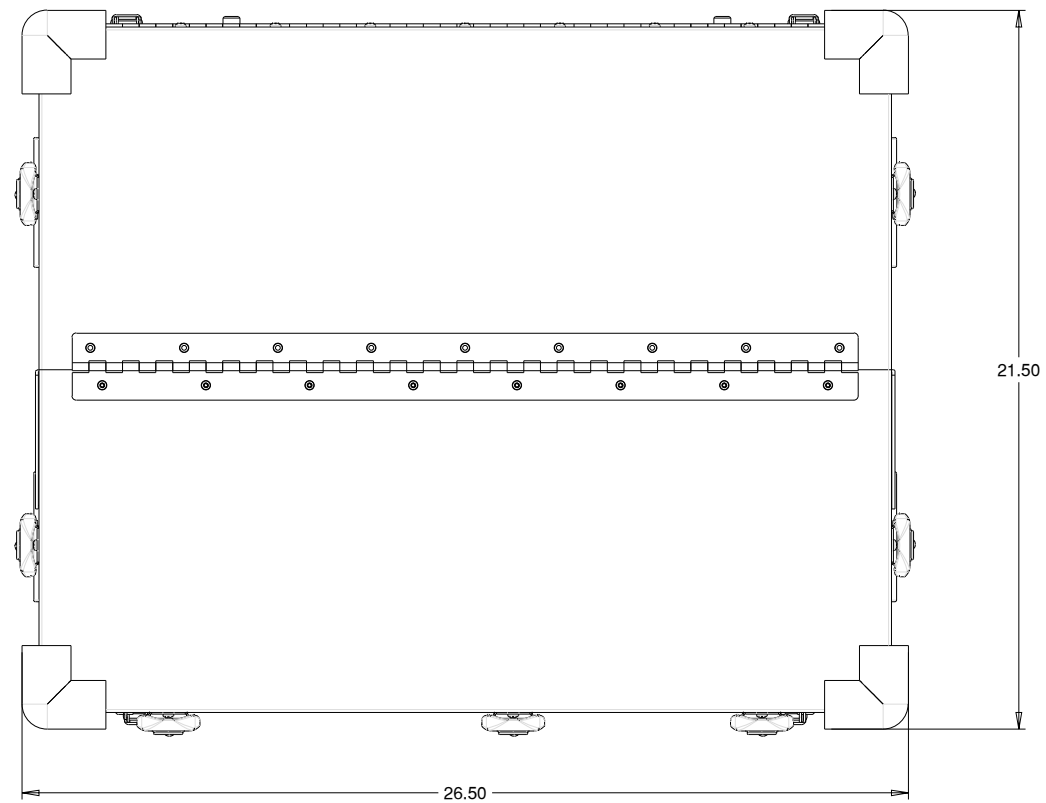

## MONITOR ENCLOSURE STOWED

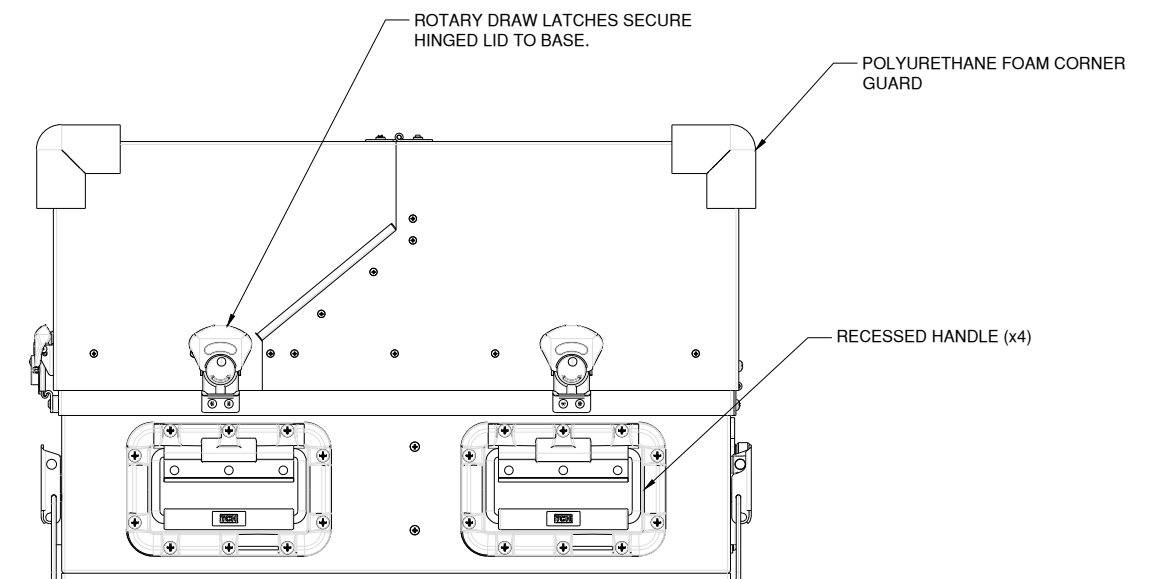
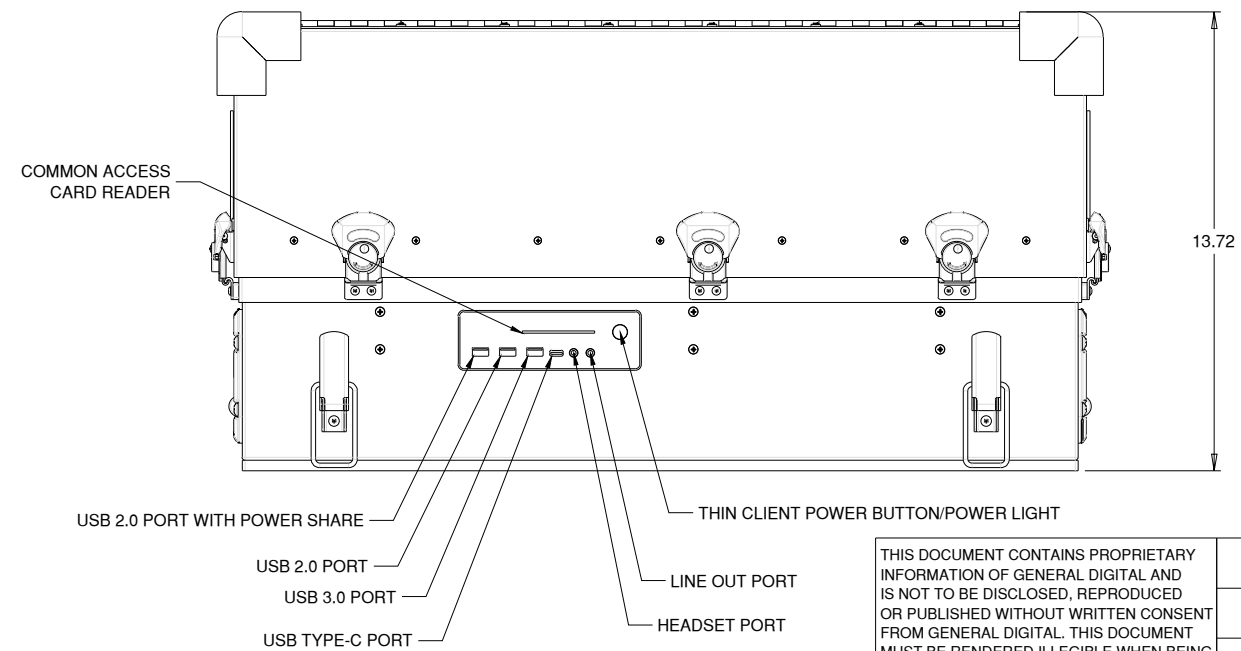

SHEET 5 OF 10

THIS DOCUMENT CONTAINS PROPRIETARY INFORMATION OF GENERAL DIGITAL AND IS NOT TO BE DISCLOSED, REPRODUCED OR PUBLISHED WITHOUT WRITTEN CONSENT FROM GENERAL DIGITAL. THIS DOCUMENT MUST BE RENDERED ILLEGIBLE WHEN BEING DISCARDED. © COPYRIGHT 2021. ALL RIGHTS RESERVED.

UNLESS OTHERWISE SPECIFIED DIMENSIONS ARE IN INCHES TOLERANCES ARE:  
FRACTIONS DECIMALS ANGLES  
±1/32 .X ±.050 ±0° 30'  
.XX ±.031  
.XXX±.020

### CONNECTOR CHART

MECHANICAL OUTLINE ONLY. SPECIFICATIONS SUBJECT TO CHANGE WITHOUT NOTICE. U.O.S. ALL DIMENSIONS ARE IN INCHES.

APPROVALS	DATE
DRAWN FA	27-Oct-21
CHECKED	
APPROVED	
DO NOT SCALE DRAWING	



60 Prestige Park Road, East Hartford, CT 06108  
(860) 282-2900 www.GeneralDigital.com

### THREE VIEW TACTILE 21.5" MONITORS

REV	DATE	ECN	DESCRIPTION	BY
-----	------	-----	-------------	----

<b>B</b>	CAGE CODE	DWG. NO.	REV
	1JA77	2215-008-97	-



# CUSTOMER APPROVAL

COMPANY  
DATE

NAME (PRINT)  
SIGNATURE

2215-008-97

90-2215-008

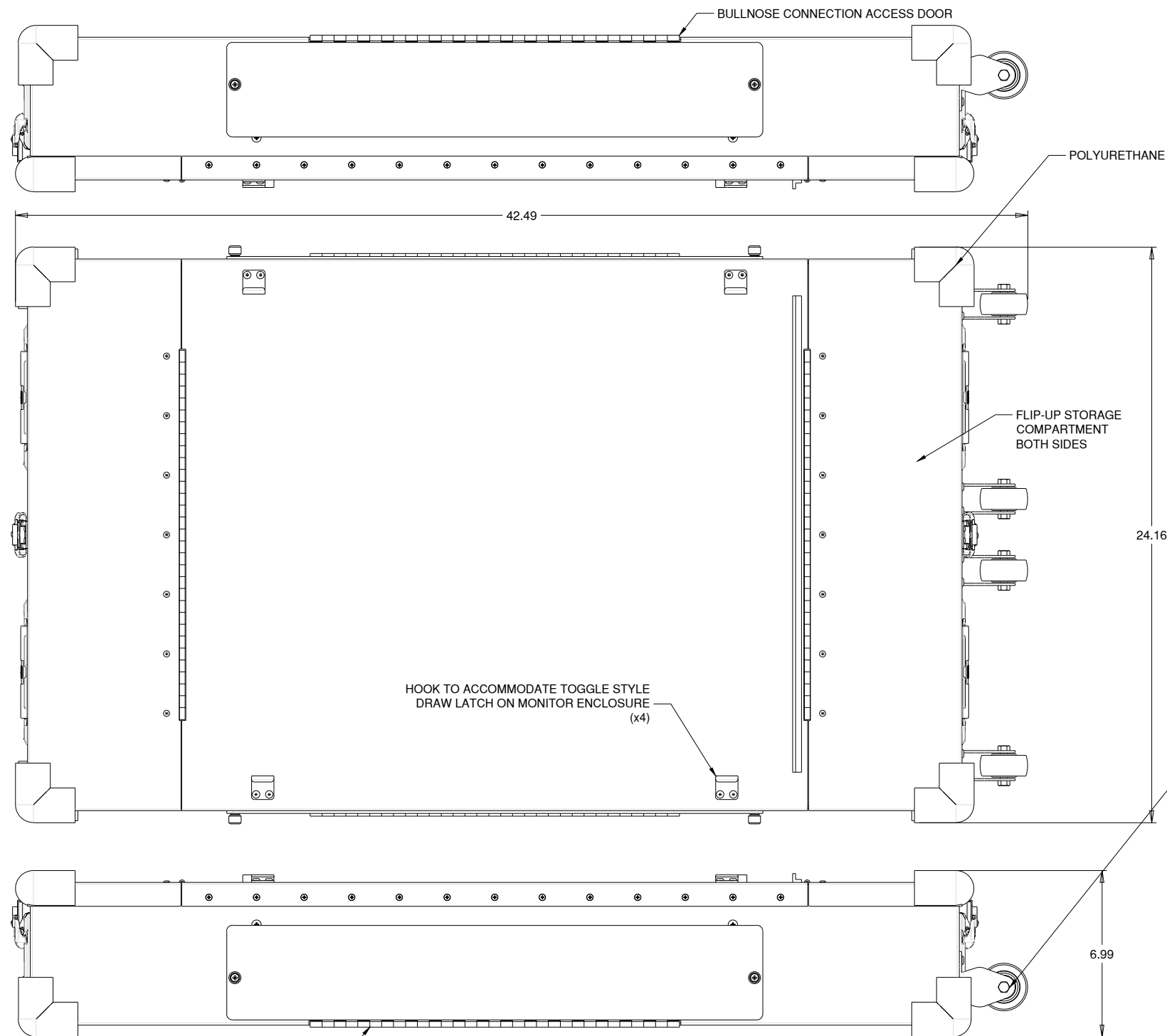

## BULLNOSE ENCLOSURE STOWED

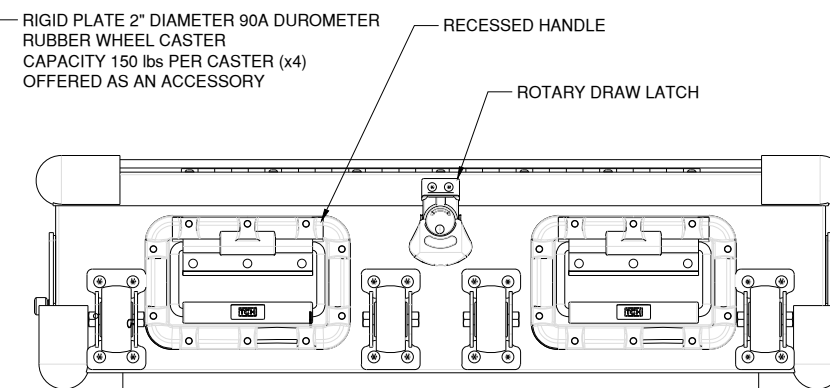
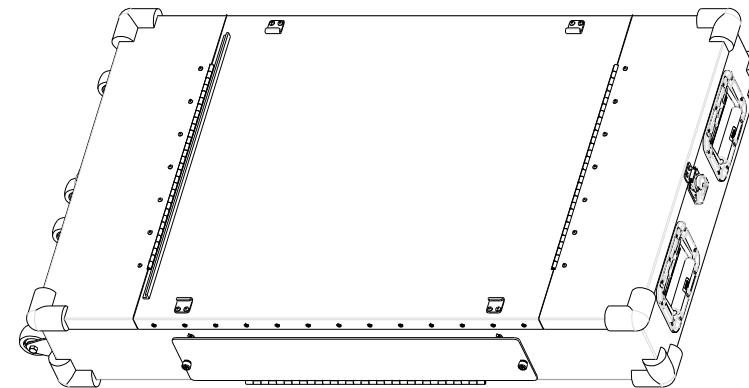

SHEET 7 OF 10

THIS DOCUMENT CONTAINS PROPRIETARY INFORMATION OF GENERAL DIGITAL AND IS NOT TO BE DISCLOSED, REPRODUCED OR PUBLISHED WITHOUT WRITTEN CONSENT FROM GENERAL DIGITAL. THIS DOCUMENT MUST BE RENDERED ILLEGIBLE WHEN BEING DISCARDED. © COPYRIGHT 2021. ALL RIGHTS RESERVED.

UNLESS OTHERWISE SPECIFIED DIMENSIONS ARE IN INCHES  
TOLERANCES ARE:  
FRACTIONS DECIMALS ANGLES  
±1/32 .X ±.050 ±0° 30'  
.XX ±.031  
.XXX±.020

### CONNECTOR CHART

NO.	DESCRIPTION	QTY.

MECHANICAL OUTLINE ONLY. SPECIFICATIONS SUBJECT TO CHANGE WITHOUT NOTICE. U.O.S. ALL DIMENSIONS ARE IN INCHES.

APPROVALS	DATE
DRAWN FA	27-Oct-21
CHECKED	
APPROVED	

DO NOT SCALE DRAWING



60 Prestige Park Road, East Hartford, CT 06108  
(860) 282-2900 www.GeneralDigital.com

THREE VIEW TACTILE  
21.5" MONITORS

REV	DATE	ECN	DESCRIPTION	BY

<b>B</b>	CAGE CODE	DWG. NO.	REV
	1JA77	2215-008-97	-

# CUSTOMER APPROVAL

COMPANY

NAME (PRINT)

DATE

SIGNATURE

2215-008-97

90-2215-008

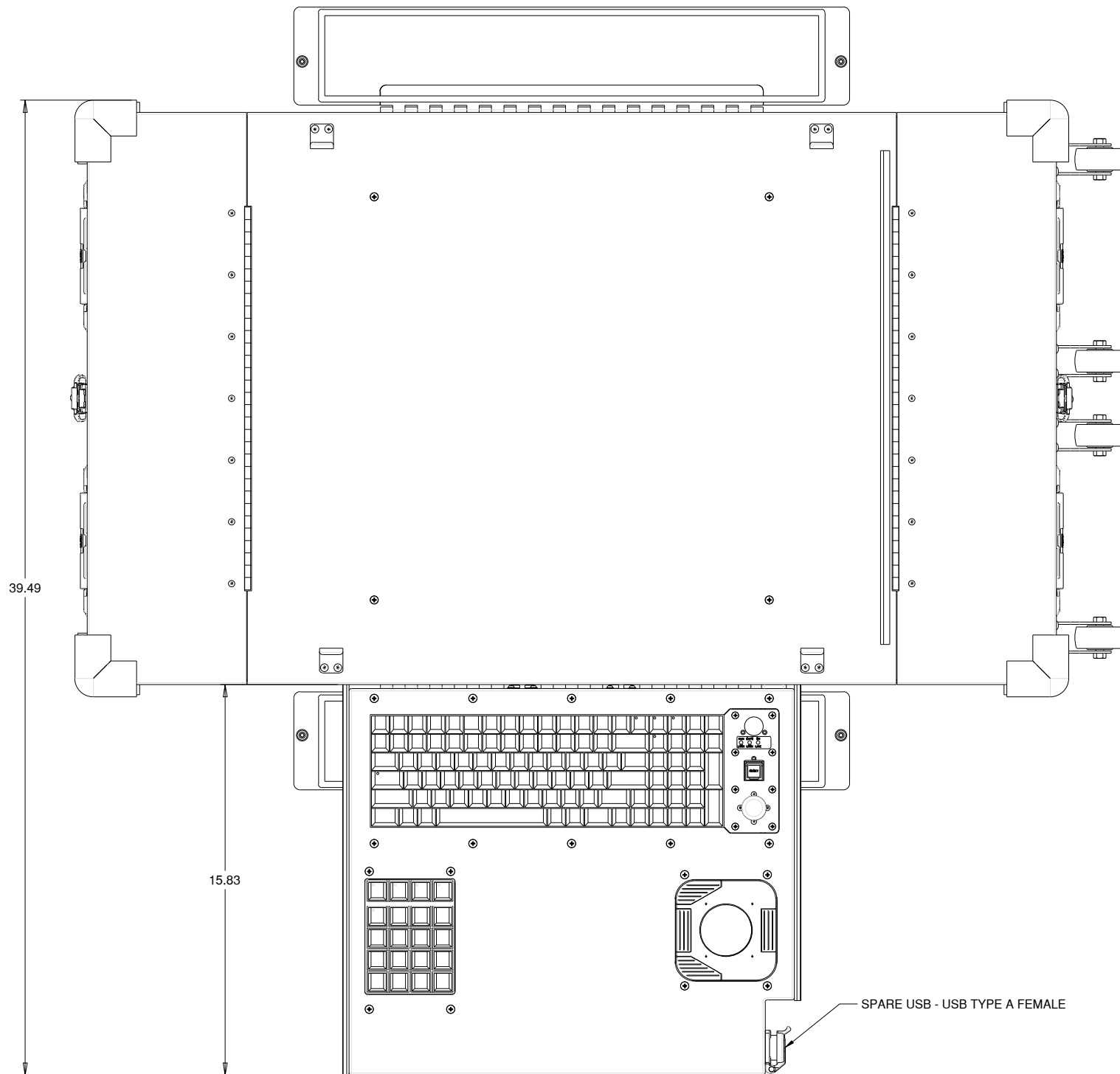

## BULLNOSE ENCLOSURE DEPLOYED

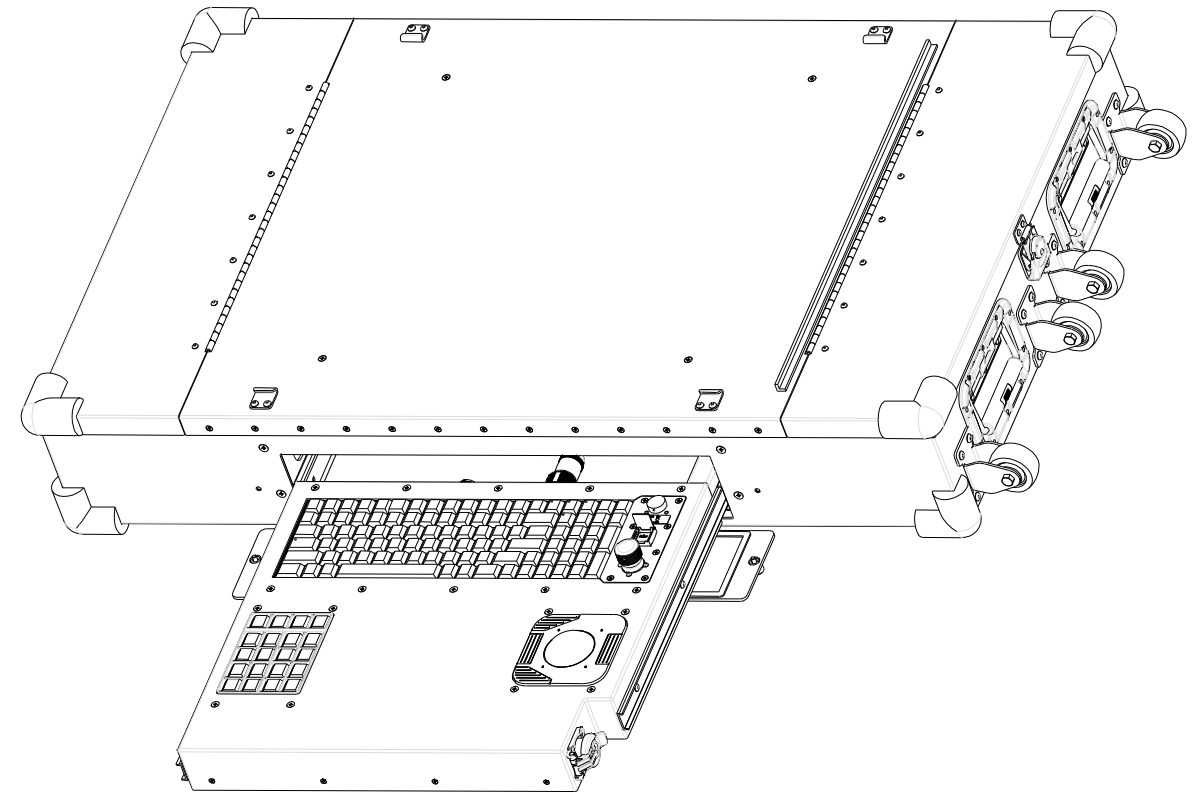

SHEET 8 OF 10

THIS DOCUMENT CONTAINS PROPRIETARY INFORMATION OF GENERAL DIGITAL AND IS NOT TO BE DISCLOSED, REPRODUCED OR PUBLISHED WITHOUT WRITTEN CONSENT FROM GENERAL DIGITAL. THIS DOCUMENT MUST BE RENDERED ILLEGIBLE WHEN BEING DISCARDED. © COPYRIGHT 2021. ALL RIGHTS RESERVED.

UNLESS OTHERWISE SPECIFIED DIMENSIONS ARE IN INCHES  
 TOLERANCES ARE:  
 FRACTIONS DECIMALS ANGLES  
 ±1/32 .X ±.050 ±0° 30'  
 .XX ±.031  
 .XXX±.020

### CONNECTOR CHART

MECHANICAL OUTLINE ONLY. SPECIFICATIONS SUBJECT TO CHANGE WITHOUT NOTICE. U.O.S. ALL DIMENSIONS ARE IN INCHES.

APPROVALS		DATE
DRAWN	FA	27-Oct-21
CHECKED		
APPROVED		
DO NOT SCALE DRAWING		



60 Prestige Park Road, East Hartford, CT 06108  
 (860) 282-2900 www.GeneralDigital.com

### THREE VIEW TACTILE 21.5" MONITORS

REV	DATE	ECN	DESCRIPTION	BY
-----	------	-----	-------------	----

<b>B</b>	CAGE CODE	DWG. NO.	REV
	1JA77	2215-008-97	-



# CUSTOMER APPROVAL

2215-008-97

90-2215-008

COMPANY

NAME (PRINT)

DATE

SIGNATURE

Feature	Value	Unit
<b>Display</b>		
Size (Diagonal)	21.5	in.
Active Area	18.765 (H) x 10.556 (V)	in.
Resolution	1920 x 1080	Pixels
Colors	16.7 Million (8-bit)	
Viewing Angle (H/V)	±89 / ±89	Degrees (°)
Refresh Rate	60	Hz
<b>Optical</b>		
Brightness (Max)	250	Nits
Dimming Range	10 - 100	%
Contrast	5000:1	
Backlight Type	LED (Single Rail)	
<b>Power</b>		
Input	90 - 264	VAC
Frequency	47 - 63	Hz
Power Consumption (Est)	TBD	W
<b>Environmental</b>		
Operating Temperature	0 - +50	°C
Storage Temperature	-20 - +70	°C
Humidity	5 - 95	%RH
Vibration	Generally Rugged	
Shock	Generally Rugged	
EMI	(Designed to Comply) MIL-STD-461	
<b>Mechanical</b>		
Finish	POWDER COAT, CARDINAL T241-BK59 BLACK	

SHEET 9 OF 10

THIS DOCUMENT CONTAINS PROPRIETARY INFORMATION OF GENERAL DIGITAL AND IS NOT TO BE DISCLOSED, REPRODUCED OR PUBLISHED WITHOUT WRITTEN CONSENT FROM GENERAL DIGITAL. THIS DOCUMENT MUST BE RENDERED ILLEGIBLE WHEN BEING DISCARDED. © COPYRIGHT 2021. ALL RIGHTS RESERVED.

UNLESS OTHERWISE SPECIFIED DIMENSIONS ARE IN INCHES  
TOLERANCES ARE:  
FRACTIONS DECIMALS ANGLES  
±1/32 .X ±.050 ±0° 30'  
.XX ±.031  
.XXX±.020

## CONNECTOR CHART

MECHANICAL OUTLINE ONLY. SPECIFICATIONS SUBJECT TO CHANGE WITHOUT NOTICE. U.O.S. ALL DIMENSIONS ARE IN INCHES.

APPROVALS DATE

DRAWN FA 27-Oct-21

CHECKED

APPROVED

DO NOT SCALE DRAWING



60 Prestige Park Road, East Hartford, CT 06108  
(860) 282-2900 www.GeneralDigital.com

THREE VIEW TACTILE  
21.5" MONITORS

<b>B</b>	CAGE CODE	DWG. NO.	REV
	1JA77	2215-008-97	-

REV	DATE	ECN	DESCRIPTION	BY

# CUSTOMER APPROVAL

COMPANY

NAME (PRINT)

DATE

SIGNATURE

2215-008-97

90-2215-008

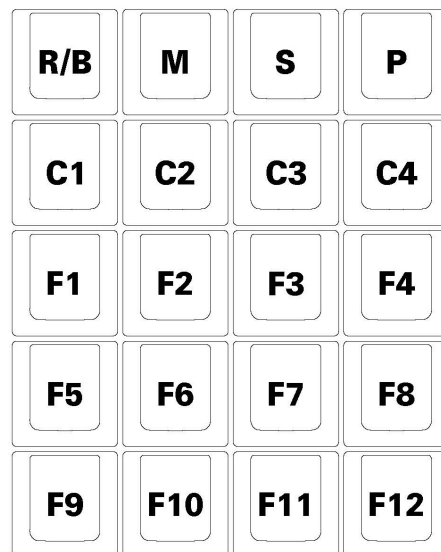

ALL LEGENDS ARE NEGATIVE IMAGE  
(TRANSLUCENT LEGEND ON BLACK BACKGROUND)

SHEET 10 OF 10

THIS DOCUMENT CONTAINS PROPRIETARY INFORMATION OF GENERAL DIGITAL AND IS NOT TO BE DISCLOSED, REPRODUCED OR PUBLISHED WITHOUT WRITTEN CONSENT FROM GENERAL DIGITAL. THIS DOCUMENT MUST BE RENDERED ILLEGIBLE WHEN BEING DISCARDED. © COPYRIGHT 2021. ALL RIGHTS RESERVED.

UNLESS OTHERWISE SPECIFIED DIMENSIONS ARE IN INCHES  
TOLERANCES ARE:  
FRACTIONS DECIMALS ANGLES  
±1/32 .X ±.050 ±0° 30'  
.XX ±.031  
.XXX±.020

## CONNECTOR CHART

MECHANICAL OUTLINE ONLY. SPECIFICATIONS SUBJECT TO CHANGE WITHOUT NOTICE. U.O.S. ALL DIMENSIONS ARE IN INCHES.

APPROVALS	DATE
DRAWN FA	27-Oct-21
CHECKED	
APPROVED	
DO NOT SCALE DRAWING	



60 Prestige Park Road, East Hartford, CT 06108  
(860) 282-2900 www.GeneralDigital.com

THREE VIEW TACTILE  
21.5" MONITORS

REV	DATE	ECN	DESCRIPTION	BY
-----	------	-----	-------------	----

<b>B</b>	CAGE CODE	DWG. NO.	REV
	1JA77	2215-008-97	-